



JL 250

Electric - hydraulic compact crane

The Crane 250

Compact

The counterbalanced crane JL 250 with hydraulic lift is the most compact on the market. Born to facilitate the lifting of light weights up to 250 kg in aisles and confined spaces. One of the strong points is the ball bearing turntable which makes the 240 ° rotary movement fluid and light, which facilitates the transport of any type of product. The crane JL250 by Just Lift has been designed to speed up and optimize all operations related to lifting and logistics, increasing productivity while ensuring maximum safety and ergonomics for the operator.

JL 250

JL120.720



4,0 km/h



250 kg



1.050 mm

- It can lift loads up to 250 kg.
- Motorized drawbar guide.
- Arm controls with wire control.
- Lift and extension with hydraulic system.
- Standard Anti-tipping system.
- 100% electric.



👁 **Front View**



👁 **Side View**



👁 **Top View**



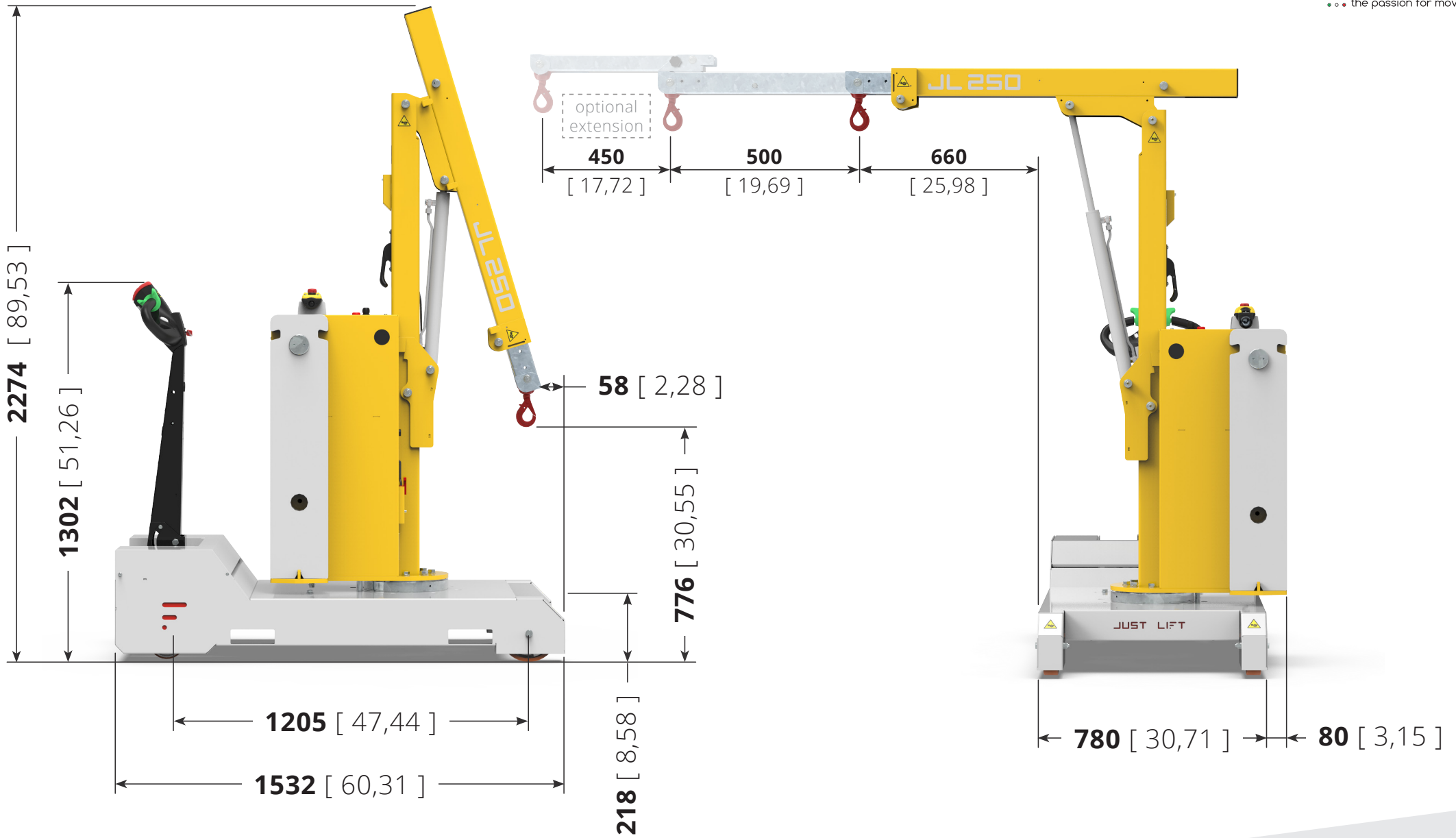

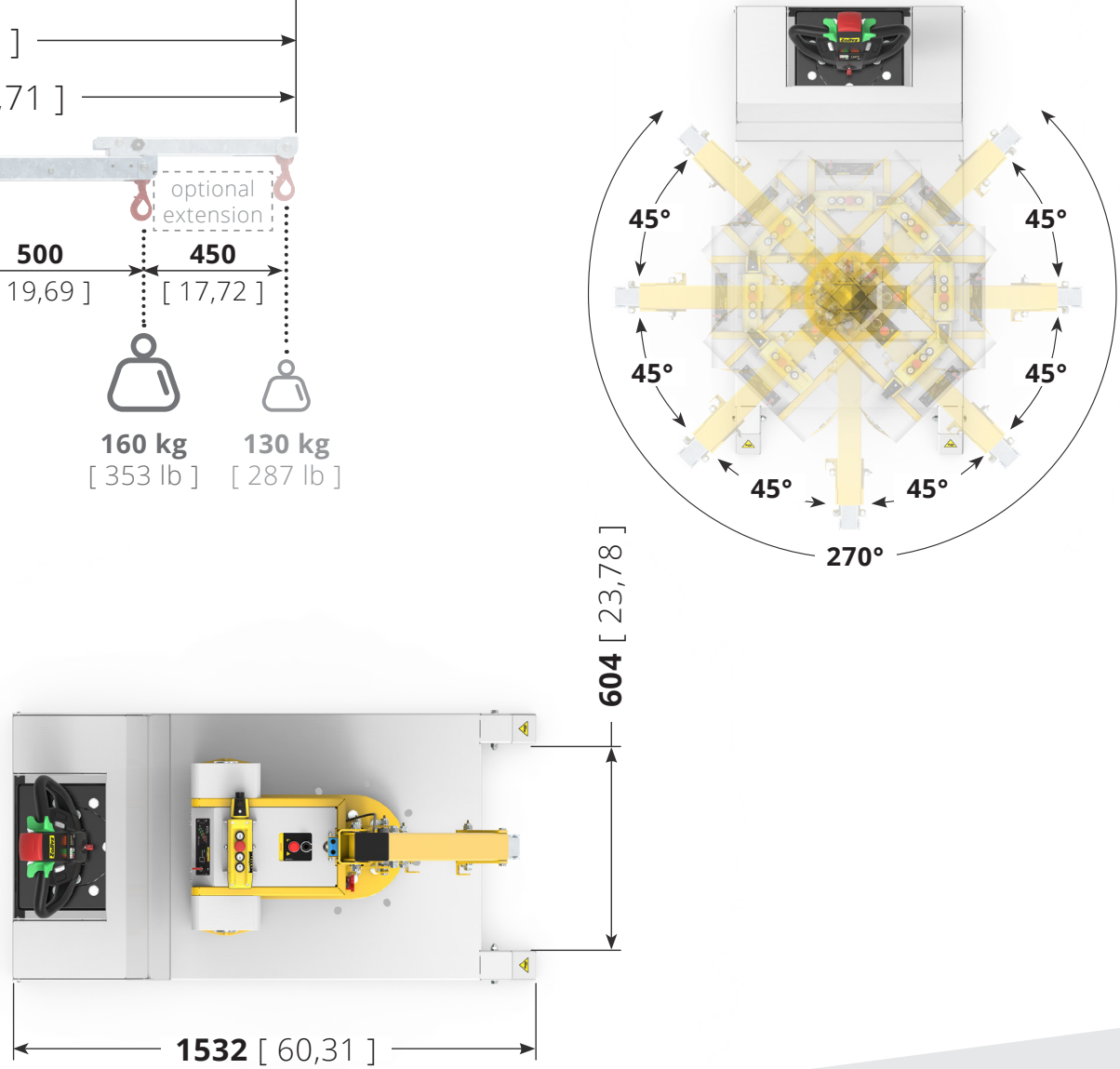
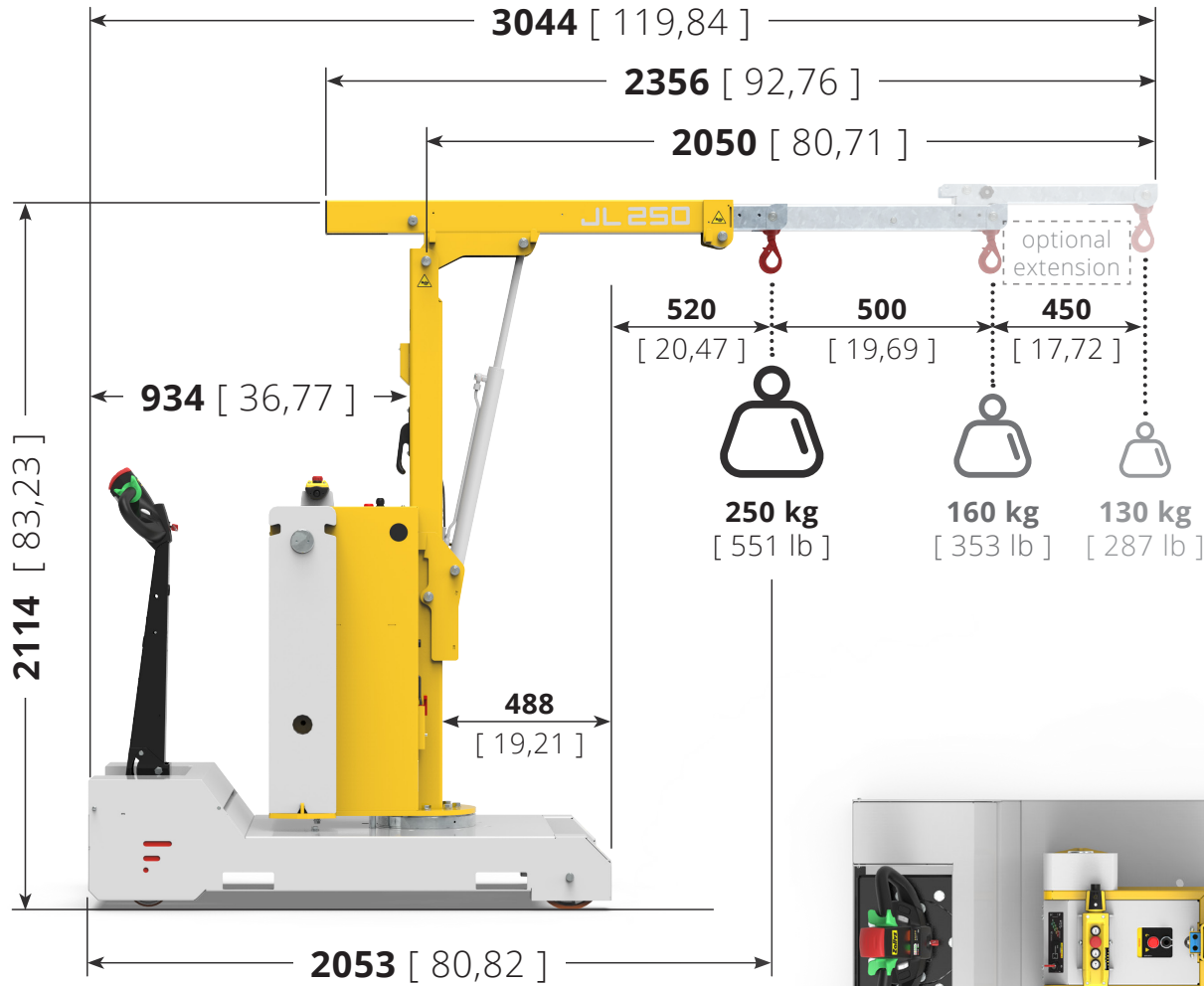

	<p>TABLE: JL120.720</p>	<p>JL 250</p>	<p>Unit: mm [inch]</p>
--	------------------------------------	---------------	-------------------------------

Ergonomic Driving

The **Zallys tillerhead** has been designed and built to make the operator's use more ergonomic by ensuring the right comfort on long use during the work shift. **Its ergonomic design** allows you to have all the control buttons at your fingertips, the display indicates the remaining battery charge and the key is situated on the top of the tiller. **The structure** is made with a strong plastic cover to resist in case of accidental impacts.



5 speed Kit

On the latest version of the tiller handle installed on model JL250 a 5 speed button is a standard feature. By pressing it, with each click, the speed switches from one gear to another.. In this way the operator can select the appropriate speed very quickly depending on the type of maneuvers is making. **The Flex to Go system** has been designed to assure a greater maneuverability in tight and driving the unit at an higher speed when a longer distance has to be covered.

Each click adds 20% more speed than the previous gear.

Speed ramp: 20% - 40% - 60% - 80% - 100%

Once in fifth gear, pressing the button returns to first gear.



5 SPEED CONTROL

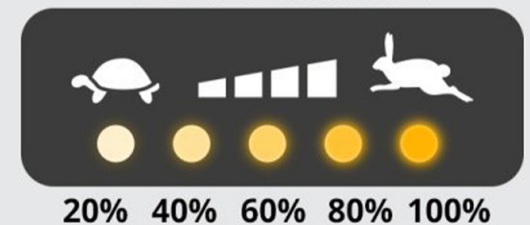



Remote control

The Just Lift JL250 counterbalanced crane has a control entirely **designed for precision** movements. The speed of movement is proportional to the movement of the stick. **Its ergonomic design** allows you to work for many hours without tiring your hand. **The structure is resistant** to impacts in the event of falls of less than one meter from the ground.

ACCESSORIES

Arm kit for every need



**EXTENSION KIT FOR CRANE
ARM 450 MM**

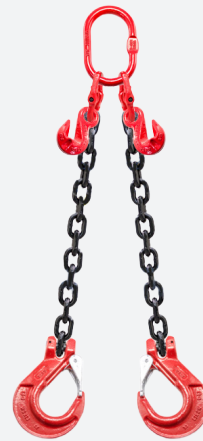

**2-ARM CHAINS WITH
SHORTENERS (GKN)**



**4-ARM CHAINS WITH
SHORTENERS (GKN)**



Examples of applications

on various production sectors



METALLURGICAL INDUSTRY





• • • the passion for moving

Zallys srl srl - Via Palazzina 1, Sarcedo
36030 (VI) - Italia

Contacts:

sales@zallys.com
+39 0445 366785

Web site:

www.zallys.com

